



## **PACE SYSTEM USER MANUAL**

A fully immersive gym lighting system designed for the fitness industry.

***Lighting Made Simple***

## **LEDSnaps PACE System User Manual Rev. B**

©2024 LEDSnaps™. The information in this document is subject to change without notice.

LEDSnaps™ and all affiliated companies disclaim liability for any injury, damage, direct or indirect loss, consequential or economic loss, or any other loss occasioned using, inability to use, or reliance on the information contained in this manual. The LEDSnaps™ logo, the LEDSnaps™ name, and all other trademarks in this document pertaining to LEDSnaps™ services or LEDSnaps™ products are trademarks owned or licensed by LEDSnaps™, its affiliates, and subsidiaries.

English Edition



## Contents

Safety information.....	2
Overview & parts identification.....	3
Preparing for installation.....	4
Installing the bracket system.....	5
End caps.....	7
Installing the Driver 4/8 Pro.....	7
Driver 4/8 Pro connections.....	7
Locking the LEDSnaps™ PACE together.....	9
Connecting corners.....	9
Top Input/Output.....	10
Using the optional Line-in kit.....	10
Using the optional Mic kit.....	11
LEDSnaps™ app.....	12
Connecting the power.....	13
Configuration.....	14
Troubleshooting.....	15
Connection diagram.....	17
Support.....	18
Product specifications.....	19

## Safety Information



### Warning!

Read the following safety precautions carefully before unpacking, installing, powering, or operating the device.



LEDsnaps™ luminaires are intended for professional use only.

This product must be installed by a Level 2 Electrician familiar with breaker installation and the hazards involved.

### **DANGER! Risk of electric shock. Do not open the device.**

- Always power off/unplug the fixture before removing covers or dismantling the product.
- Ensure that the mains power is off when wiring the device to the AC mains supply.
- Ensure that the device is electrically connected to earth (ground).
- Do not apply power if the device or mains cable is in any way damaged.
- Do not immerse the fixture in water or liquid.

### **WARNING! Take measures to prevent burns and fire.**

- Install in a location that prevents accidental contact with the device.
- Install only in a well-ventilated space.
- Install only in accordance with applicable building codes.
- Do not paint, cover, or modify the device, and do not filter or mask the light.
- Keep all flammable materials well away from the device.
- Allow the device to cool for 15 minutes after operation before touching it.

### **WARNING! Take measures to prevent personal injury.**

- Take precautions when working at height to prevent injury.
- Ensure cables are securely fastened/held to avoid the weight of the cable pulling on the PACE bars.

## Overview

The LEDSnaps™ PACE system is a fully immersive linear RGB LED controllable fitness lighting system. Designed to fill the roof and wall space with up to 8 outputs of linear lighting, this system can provide everything from house lighting, tranquil mood lighting or fast and explosive lighting which can sync to the BPM of music.

Pre-installed lighting effects

- House lights - Three colour temperatures to choose from.
- Colour Picker - Static colours with brightness control to match the mood.
- Slow Effects - Slow and gradual colour changing effects.
- Fast Effects - Faster colour changing and explosive effects.
- Music to light - Linear lighting effects triggered by the BPM of the music.
- Standby - Turn all effects off

## Parts Identification and Terminology

A: Infrastructure suspension hardware  
– standard 1m cable (custom lengths upon request)

B: Existing suspended ceiling hardware

C: Track adapter hardware

D: Flat ceiling hardware

E: Surface mount hardware

F: Turnbuckle

G: Thumbwheel

H: Turnbuckle screws

I: Turnbuckle plate

J: PACE 1200 | 600 | 400

K: PACE 1200 | 600 Top Input/Output

L: 90° flat PACE corner – Left

M: 90° flat PACE corner – Right

N: Inside PACE corner

O: Driver 4 Pro

P: Driver 8 Pro

Q: Control Panel – 10" Tablet

R: Line-in kit

S: Mic kit

T: Splicing kit (available in different lengths if required)

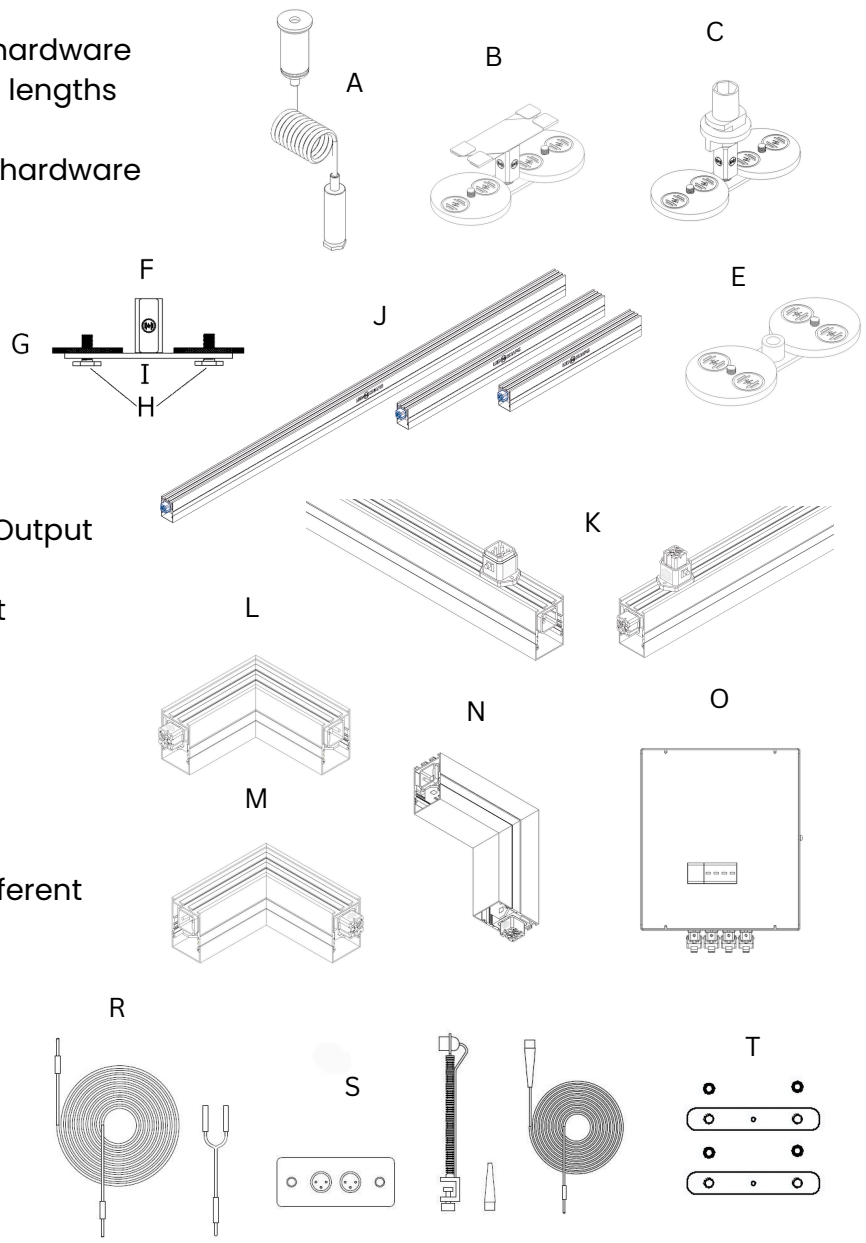

## Preparing for Installation

### Unpacking

Unpack the lighting system to ensure it is complete and has not suffered any damage in transit. The LEDSnaps™ system will be shipped with:

- 1 x Control Panel with our LEDSnaps app
- 1 x Control Panel wall mounting bracket.
- 1 x LEDSnaps™ Driver 4/8 Pro unit.
- 2 x mounting hardware per LEDSnaps™ PACE 1200 | 600 | 400 (supplied as per customer requirement).
- Up to 8 x starter cables (supplied as per customer requirement).
- Up to 8 x end of run end caps to cap off the socket on the final light bar of a run (supplied as per customer requirement).
- Cable end caps supplied anywhere a cable is plugged into a PACE 1200 | 600 | 400 (supplied as per customer requirement).
- Up to 40/80 x LEDSnaps™ PACE 1200 | 600 | 400 with a maximum of 20 per output, not exceeding 40/80 PACE bars per Driver 4/8 Pro (one corner piece is the equivalent to a PACE bar).
- Link cables to bridge gaps/obstacles (supplied as per customer requirement).

### OPTIONAL ACCESSORIES

- 1 x Line in kit including line gain amplifier and associated cables
- 1 x Powered mic kit

### Location

- Ensure the ceiling areas to which the LEDSnaps™ PACE 1200 | 600 | 400s will be installed are clean and dry.
- Ensure there will be no accidental contact from people, doors, or moving equipment.

The standard lighting effects are directed away from the controller, so to give your gym space a sense of movement in the right direction, make sure your spin class is facing the controller.

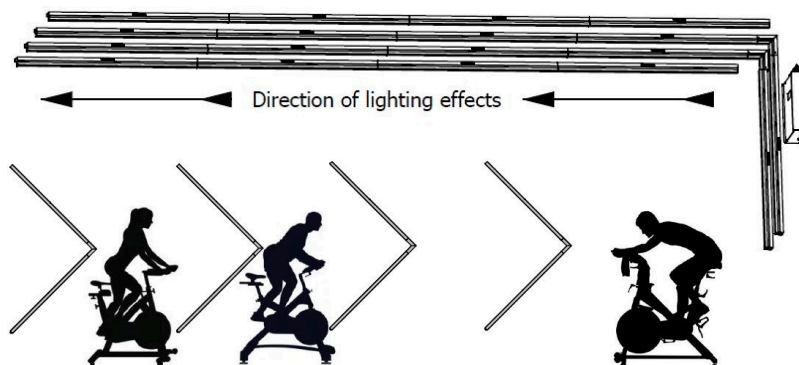

### Transportation

Use the supplied packaging or a suitable flight case for transportation and storage. Should you require LEDSnaps™ branded soft carry cases, please get in touch. Never carry the fixtures by cables or wires.

## Installing the bracket types

### Infrastructure Suspension Hardware

To install the suspended ceiling bracket, start by simply clipping the scissor clip to the ceiling grid work between the ceiling tiles, spacing them 600mm apart for even weight distribution of the PACE bars.

You will also be supplied with one safety cable kit per PACE. These are to be fitted in the middle of each PACE with the cable looping over the ceiling grid. The ceiling tiles should fall comfortably with the cable fitting between the tile and ceiling grid.

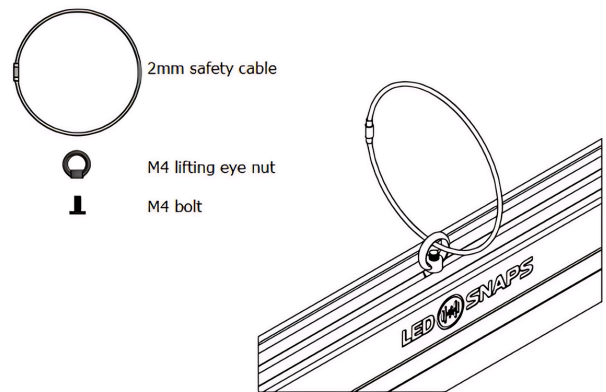

### Flat Ceiling Hardware

To install the flat ceiling hardware, start by marking on your ceiling where the brackets will be affixed. These should be spaced 600mm apart for even weight distribution of the LEDSnaps™ PACE bars. Ensure the installation is perfectly linear, or the PACE bars will not fit together. Fix the low ceiling plate to the ceiling using the supplied M6 screws and wall plugs. If needed, an installation template is included on page 17.

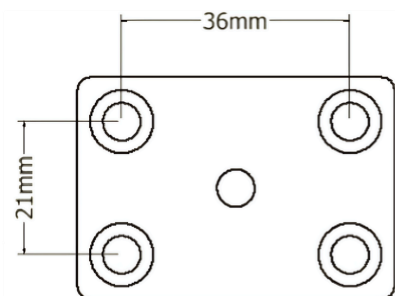

### Track Adapter Hardware

To install the track adapter hardware, simply insert and twist the track light fitting into your existing track light system.

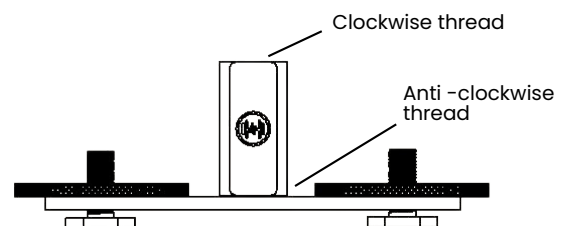

LEDSnaps™ will not draw any power from your track light so your current power configurations need not change. This is an attachment fitting only. The threaded rod and nut will be pre-fitted to ensure a good fit inside the track light fitting. Simply drop the threaded rod into the fitting and screw it onto the turnbuckle.

### Existing Suspended Ceiling Hardware

To ensure your PACE bar system is installed in a straight line we recommend the use of a standard laser alignment tool from your local hardware store. To install the existing suspended ceiling hardware first mark on your ceiling the line your lighting is to follow. Your first fixing point should be 300mm in from the start of your first PACE bar, and every 600mm throughout the installation. This will ensure a centred fitting and equal force on each cable.

Once bars are level, simply slide together.

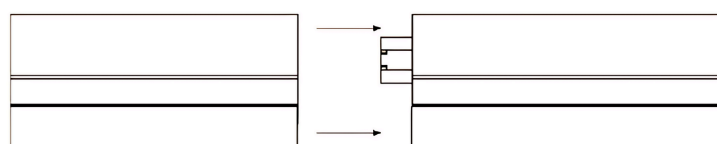

The silver hardware made of 2 pieces will attach to your ceiling. Unscrew these and use an appropriate screw to attach the larger piece to the ceiling. Once secured into place screw the two pieces back together. Now you can insert the cable into the fixed base until you can see it coming out of the hole.

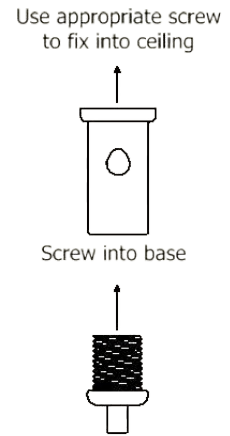

The cable will lock into place, but should you need to adjust it, simply push the point where the cable enters, and it will release the cable. The black hardware is made of 3 pieces. This time simply loosen the hex bolt enough to slide onto the back of the LEDSnaps™ PACE bar and move into place and tighten.

Then take the other end of the cable and insert it into the hole end of the black piece until you reach your desired length of cable. This will lock into place, but can be adjusted as with the ceiling end, by pushing where the cable enters. Once all your LEDSnaps™ PACE bars are installed and you're happy with the position and height, you can cut the excess cable.

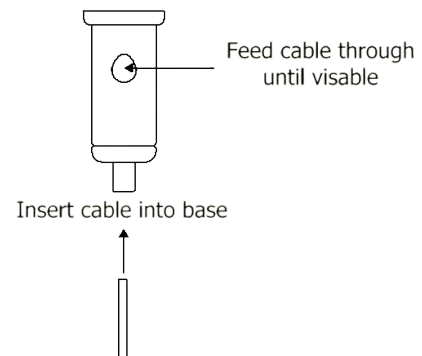

### Suspended Ceiling Installation

Suspended ceiling brackets have a scissor clip fitted to the thumbwheel bracket at the factory and are supplied in pairs with a safety cable. Slide the first bracket that has the scissor clips onto the PACE bar followed by the safety wire (this sits in the centre) and then the second bracket.

Take a LEDSnaps™ PACE bar in both hands and line up the channel on the back with the thumbscrew bolts you've left very loose and slide the PACE bar into position. Once in place use one hand to tighten the thumbscrews from beneath the PACE bar to lock it in place. Do this for both brackets before moving on to the next PACE. After the first PACE bar, you will need to connect the following unit to the preceding using the supplied splicing kit. This ensures that there is no movement between the lighting units.

### Surface Mount Hardware

To install the flush mounts first mark on your wall or ceiling the line your lighting is to follow.

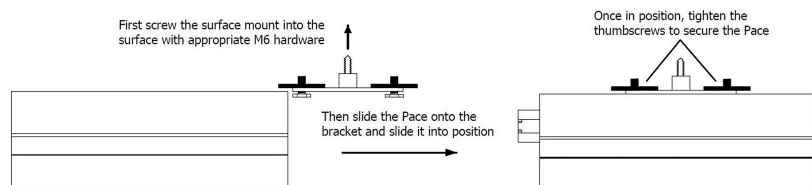

Your first fixing point should be 300mm in from the start of your first LEDSnaps™ PACE bar, and every 600mm throughout the installation. This will ensure a centred fitting and equal force on each cable.

When installing the second PACE bar onwards in any line, it will need to be pushed into place slightly ahead of the previous, then slide back onto the previous PACE bar to mate the connectors.



## End Caps

You will be supplied with two types of end caps: a larger cap for the final PACE bar in a run, to cover the protruding socket; a smaller open-end cap to surround a start or link cable, at the beginning of the line of PACE bars.

Each end cap must be secured in place with the supplied M1.5 self-tapping screws.

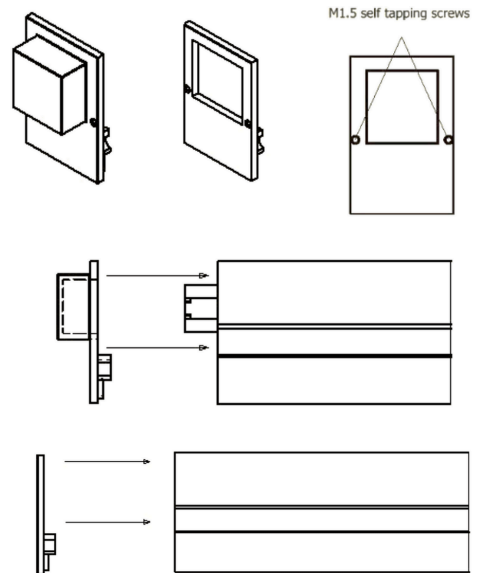

## Installing the Driver 4/8 Pro

The location of the Driver requires some thought as there are two factors to consider.

- The Driver 4/8 Pro must be mounted in a position that is accessible. There are four Miniature Circuit Breaker (MCB) switches on the controller to control the AC power feeding each LEDSnaps™ PACE. This must be fused with an MCB to meet safety standards. If an MCB does trip you will need to be able to easily reach them to reset the power – after having checked for any faults in the LEDSnaps™ PACE connections.
- The Driver 4/8 Pro can operate many LEDSnaps™ PACE units. Due to this you may need to connect your Driver 4/8 Pro to the fuse box directly with its own MCB. See page 13 for limits.
- Install the Driver 4/8 Pro where power can be easily routed, and the starter cables can still easily reach the first PACE bar of each output.

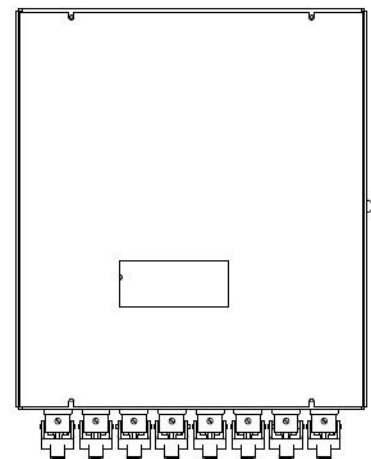

Once you have decided on the ideal location, remove the lid of the driver, there are 4 holes in the rear panel of the driver to affix the driver to a surface such as a wall. Make sure you will be installing the mounting screws into a hard material (wood, brick, concrete), and not a cavity wall. Use suitable screws and plugs to secure the Driver to your surface of choice.

## Driver 4/8 Pro Connections

On the Driver 4/8 Pro you will see a 3.5mm port to connect your Line In Kit or Microphone Kit for light response to sound, two ethernet sockets and an SD card slot.

If you are using more than 1 Driver, the Drivers will come pre-labelled as a 'Master' and 'Slave'. To connect a slave to the master a CAT5 cable must be connected to the output of the master and the input to the slave. Please connect them together using the network ports on the top of the Drivers.

The SD card slot is for the provided SD card, which has your lighting sequences preloaded. This only needs to be removed in the event of an SD card fault, or to upload new lighting sequences.

**PLEASE NOTE:** The SD card must be fitted with the label facing the front of the Driver.

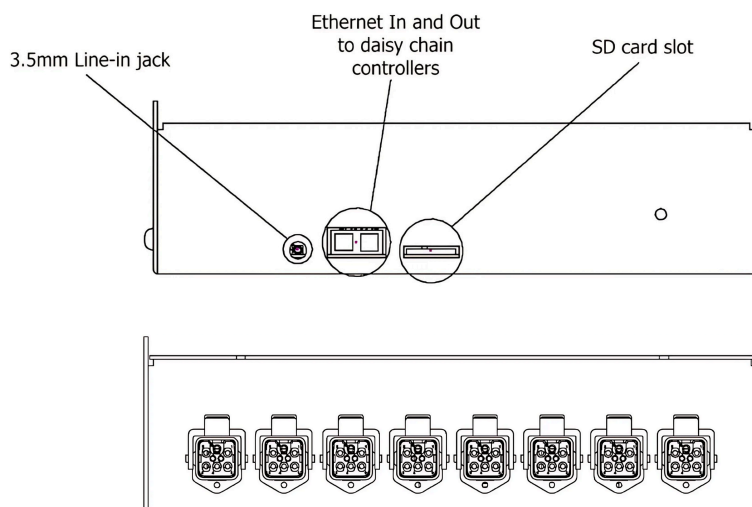

On the base of the Driver 4/8 Pro there are 4/8 LEDSnaps™ PACE outputs. Each output can control up to 20 PACE units, however a maximum of 40/80 PACE bars in total per Driver 4/8 Pro cannot be exceeded.

Your starter cables will clamp into these sockets and carry the data and power to the PACE bars.

You will notice that your starter cable will look slightly different to your link cables (if supplied). The starter cable will have two spigots on the connector housing to securely clip the connector to the Driver 4/8 Pro.

1. Slide the connector onto the housing on the Driver 4/8 Pro matching up the spigots on the side of the connector. The connector will only mate one way, so if it doesn't fit, flip it over.
2. Once fully inserted, pull the lever lock down to lock the spigots into the socket housing.

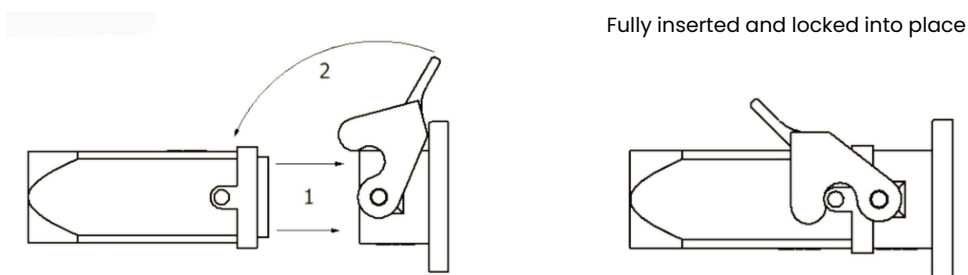

The other end of your starter cable will have a housing without the spigots and will simply slide together.

Before installing the starter cable into the first PACE bar, fit the open-end cap following the instructions on page 7. The connector again will only mate one way, so if it does not fit, flip it over.

Push the connector all the way in, and your first LEDSnaps™ PACE bar is installed.

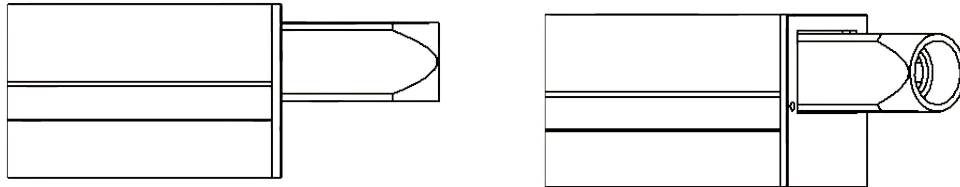
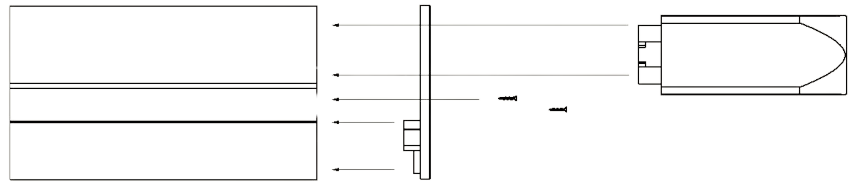

### Locking the LEDSnaps™ PACE together

When installing subsequent LEDSnaps™ PACE bars you will need to lock them together using the splicing kit, which simply requires the tightening of four grub screws with the included Allen key. The splicing bars are to be fitted on the top of each PACE bar.

Use the included 2mm Allen key to tighten the grub screws

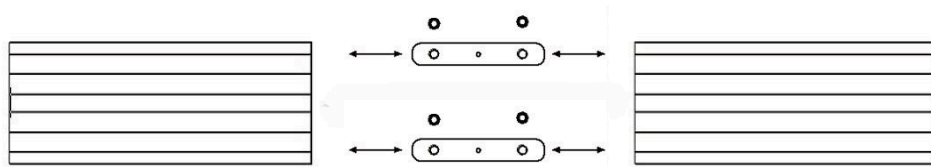

Slide the splicing kits into the two outer channels.  
Use the holes to locate the correct positions.

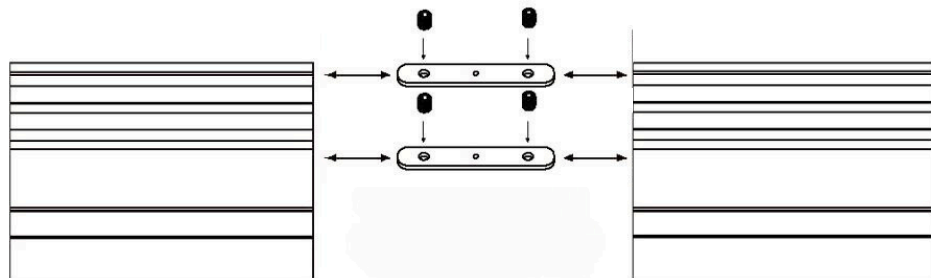

### Connecting Corners

PACE corners are not supplied with brackets and need to be locked into the PACE bars they are connected to with the splicing kit mentioned above.

When installing the PACE bars, ensure that the direction of the connectors match the direction your corners face when installed. The inside corner can be easily flipped around, but the flat corners are direction specific and labelled by their direction when installed and viewed from the floor.

If you have had an installation specified by our Sales or Design team the orientation of your corners will be determined by the design.

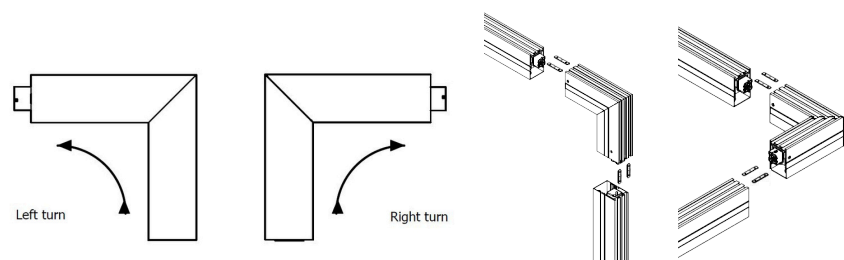

## Top Input/Output

Depending on the type of ceiling you have and having discussed this with our sales team your PACE bar system may have adapted PACE bars with extra sockets mounted on the top. These are to be used to help the aesthetics of the installation or when making a square or rectangle configuration. If you have consulted our team on your design, we will have supplied a wiring diagram showing where each type of PACE bar is to be fitted.

**NOTE: You must check that all your brackets and splicing kits are tightened and the LEDSnaps™ PACE bars do not come apart or slide on the brackets.**



**DO NOT TURN ON THE POWER UNTIL THIS CHECK HAS BEEN DONE**



**IMPORTANT, DANGER OF ELECTRIC SHOCK. You must fit the end cap to the last LEDSnaps™ PACE bar in each run to cover the output socket, failure to do so could result in an electric shock if someone were to push a foreign object into it.**

## Using the optional Line-in Kit

The LEDSnaps™ PACE System is available with optional audio kits. The Line-in kit is supplied with a small amplifier which requires power from a standard 13-amp socket.

Connect the input of the amplifier to a line output of your audio source. Connect the output of the amplifier to the 3.5mm socket on top of the LEDSnaps™ Driver 4/8 Pro, the plug can be a snug fit and please ensure you push it in fully. There is a gain knob on the amplifier we recommend turning this fully clockwise and then turn it back down by 10-15%.

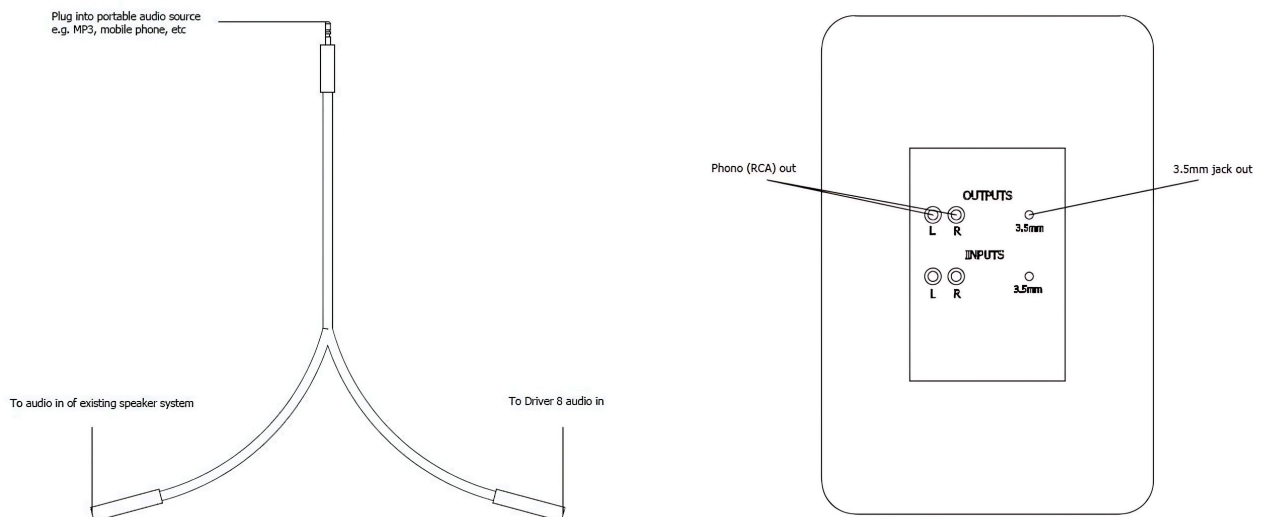

If you use your own personal audio source (mobile phone, tablet, laptop, etc.) into a speaker system for your class, you will need to use the 3.5mm splitter to split the audio signal allowing you to send the audio to both the speaker system, and the Driver 4/8 Pro.

The sensitivity slider on the left of your Control Panel will provide you with live sensitivity adjustment to match your music style. High tempo or very loud music will require the sensitivity to be reduced, whereas quieter or reduced tempo music will require a higher sensitivity.

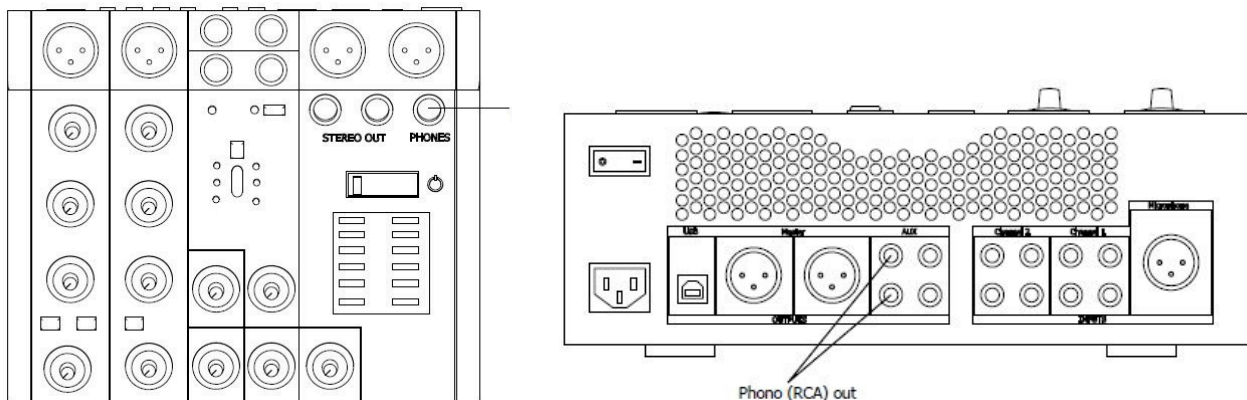

### Using the optional Mic Kit

To use the powered microphone, it must be installed near to a speaker using the included clamp to pick up on the sound and feedback the tempo in the Music to Light mode.

The microphone has a cable with a XLR socket which needs to be plugged into the Mic amplifier, the amp has a small switch that must be pressed in to supply power to the microphone. The amplifier needs to be connected to a standard 13-amp style socket. The output of the amplifier needs to be connected to the audio using the 3.5mm socket on the top of the Driver 4/8 Pro with the supplied cables.

We would recommend turning this clockwise to maximum, then back slightly to avoid interference in the signal.

The sensitivity slider on the left of your Control Panel will provide you with live sensitivity adjustment to match your music style. High tempo or very loud music will require the sensitivity to be reduced, whereas quieter or lesser tempo music will require the sensitivity to be increased.

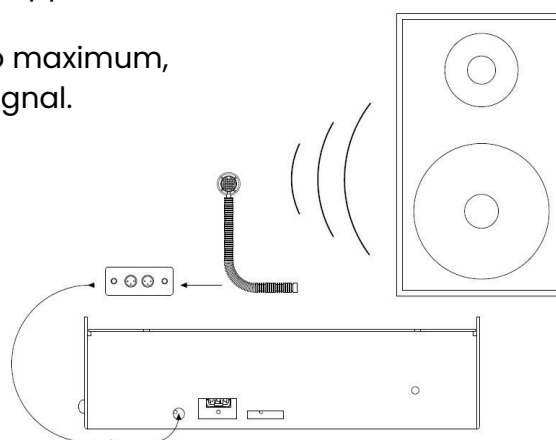

To test the microphone, clap your hands and note if the red LED on the amplifier flashes. If it doesn't you need to press the black button on the amplifier to supply power to the mic.

## Control Panel

The Control Panel supplied with your PACE system will have our app rooted to it, so when you turn it on, the app will start. Once you turn the Control Panel on, the app will then scan for an available Wi-Fi signal.

The Driver 4/8 Pro creates its own Wi-Fi network called WIFI\_LED\_\*\*\*\*. Your control panel will come pre-synced with the Driver 4/8 out of the box, if for whatever reason they are not synced please follow the steps below.

1. Unlock the tablet by double-clicking the standby button on the rear of the tablet
2. Once unlocked, swipe your finger from the bottom of the screen upwards to activate the navigation bar and select the circle shaped button. This will minimise the LEDSnaps™ app and bring up the tablets Home Screen.
3. Swipe your finger upwards from the centre of the screen. Select the settings icon.
4. Simply select the network with the prefix WIFI\_LED\_\*\*\*\*, input password "12345678".
5. Select the square shaped button on the navigation bar to bring up the LEDSnaps™ app screen minimised, then click on it to maximise it.
6. If this has been successful, lock the screen by double-clicking the standby button again. If not, please contact us for technical support.

There is a mounting bracket supplied with the controller to mount to a wall. The app can be viewed in either landscape or portrait mode, but we think it looks best in landscape.

A DC power supply is included, and the tablet is also capable of receiving power over ethernet (PoE) so you can simply use a network cable (Cat5) and a PoE adaptor if this is more convenient.

## LEDSnaps app

Our app has been specifically designed to work with LEDSnaps™. It will automatically connect to the LEDSnaps™ Control Panel once paired and provide seamless control over the lighting sequences. Simply select the type of effect you would like, then select the colour, brightness, and speed (if applicable to the effect).

### App Home Screen

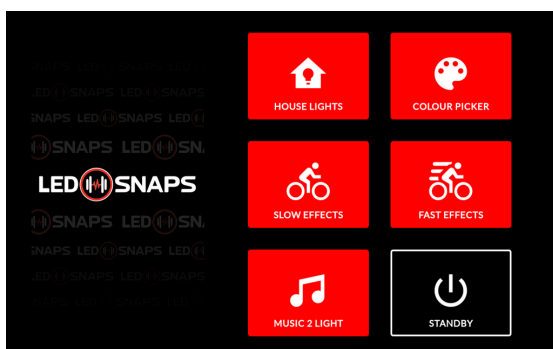

### House lights

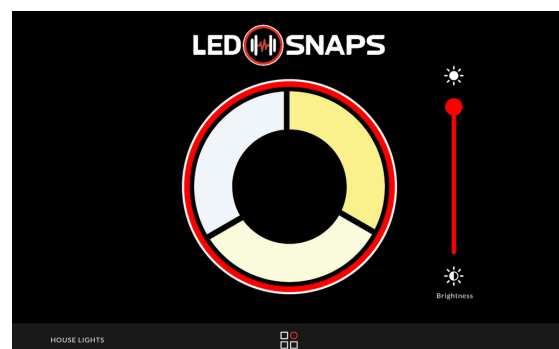

## Colour Picker

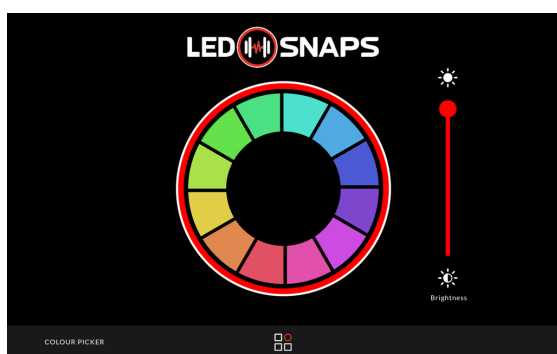

## Slow Effects

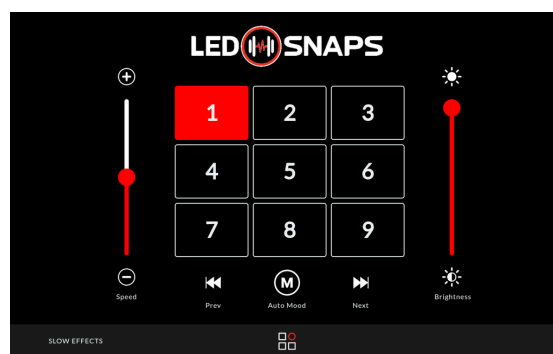

## Fast Effects

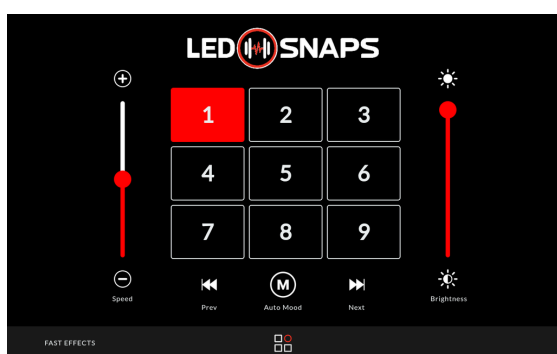

## Music 2 Light

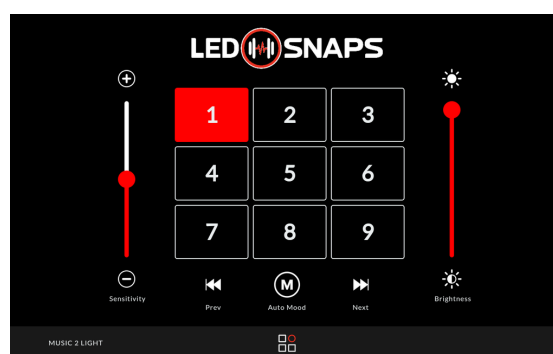

## Connecting the power

The LEDSnaps™ Driver 4/8 Pro operates on a 208-240V, 50/60 Hz AC mains power supply. Connect the Driver 4/8 Pro to AC power by connecting the mains cable to the mains breaker directly with a Type C MCB capable of handling the number of PACE connected – please see the summary below. This is because the Driver 4/8 Pro can power up to 40/80 LEDSnaps™ PACE which draws more power than a standard 13A 3-pin plug can supply. Further protection from this current is provided on the controller itself with 4 MCB switches and inrush current limiters. Each of the 4 on-board MCB's will control the flow of current to 2 outputs, and so a maximum of 20 LEDSnaps™ PACE can be installed into each output, not exceeding 40 PACE units in total per Driver 4 Pro unit and 80 PACE units in total per Driver 8 Pro.

**PLEASE NOTE: If wiring 10+ PACE bars from 1 output, ensure the paired output is clear to prevent the corresponding MCB from overloading (see line diagram on the face of the driver for reference).**

<u>Up to 10 PACE</u>	<u>10A Type C MCB</u>
<u>10 to 20 PACE</u>	<u>16A Type C MCB</u>
<u>More than 20 PACE</u>	<u>32A Type C MCB</u>

**NOTE: Your installer will need to supply and install an appropriate cable length and rating to connect the controller to your main breaker.**

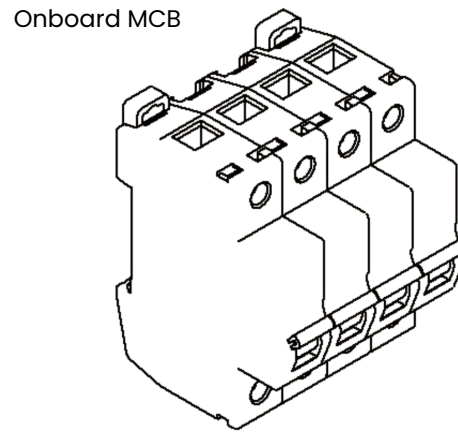
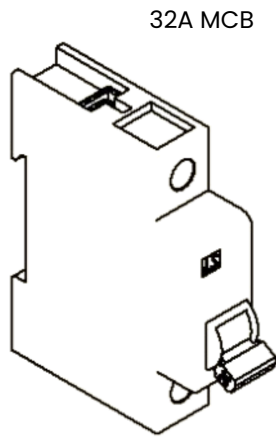

The cable colour coding is given below.

	Colour
Live	Brown
Neutral	Blue
Earth	Green/Yellow

**NOTE: A qualified level 2 electrician should manage the electrical installation.**

Once the Driver 4/8 Pro is connected to the mains you will see a red LED on the side of the controller to indicate it is receiving power.

Turn on the Control Panel, wait a few moments for them to connect to each other, and you're ready to go.

### Configuration

Our LEDSnaps™ PACE system has been designed to be easy to install which allows your electrician to complete the installation. Our pre-programmed app allows you to plug-and-play straight away.

If you would like to expand your lighting sequences and have custom lighting effects added to your list of effect, please get in touch on [info@ledsnaps.com](mailto:info@ledsnaps.com), or call +44 (0) 1233 423 360.



## Troubleshooting

Should you encounter any sort of problem with your LEDSnaps™ lighting system refer to the troubleshooting guide below and then, if necessary, contact us on [info@ledsnaps.com](mailto:info@ledsnaps.com) , or +44 (0) 1233 423 360.

Problem	Potential cause(s)	Remedies
The Driver 4/8 Pro does not respond or appears to be off.	No power to the Driver 4/8 Pro.	Confirm the MCB switch at the fusebox is in the 'on' position.
	Internal electrical fault.	Contact LEDSnaps™ for advice.
Not all PACE bars are lighting up.	Poor connection between PACE bars.	Disconnect the power and check all connections between each PACE bar. Then ensure all brackets and splicing kits are secure.
	Incorrect number of PACE bars fitted or connected to the wrong outputs.	Check you have installed the PACE bars according to our wiring diagram.
Error 5 on the Control Panel.	The SD card is not fitted or is not inserted correctly.	Check the SD card is fitted if it is then press it once to extract it and then place it back into the port and ensure it clicks into place.
After a while the Control Panel stops talking to the lights.	It is likely that during the installation, the Control Panel was connected to another Wi-Fi network within the building.	See Control Panel section in this guide and ensure the Control Panel is connected to the LEDSnaps™ Driver. The Control Panel will show any other Wi-Fi networks in range, make sure you 'forget' those networks in the settings.
The Control Panel is not sending commands to the Driver 4/8 Pro.	Loss of Wi-Fi connection.	Make sure the Control Panel is connected to the LEDSnaps™ Driver 4/8 Pro via Wi-Fi.
The lights do not move to the beat in Music to light mode.	No audio connection.	Check you have connected the microphone to the Driver 4/8 Pro or check the cable from your audio system. Ensure the Phantom power button is switched on and the gain turned to approx. 90%. If you are using a line-in kit. Ensure the gain control is turned up on the LEDSnaps™ amplifier.
Tablet is on and connected by wifi but there is no light output or some lights just have a few led's on.	Driver lost connection to the tablet, can be caused by power outs.	Turn the power supply off to the Driver(s) via the breaker, then power back on and wait 5 mins for the tablet to re-connect, if this doesn't work restart the tablet by disconnecting the power to the tablet.

<b>Problem</b>	<b>Potential cause(s)</b>	<b>Remedies</b>
Some lights are moving in the wrong direction.	Cables have been plugged into the wrong outputs on the driver.	Check you have plugged the right cable into the right output of the driver according to our wiring diagram.
Control Panel will not turn on.	Power supply disconnected.	Check power supply.
	Power button turned off.	Check power button at the rear bottom right corner of the Control Panel.

## Connection diagram

From the Control Panel to the Driver 4/8 Pro unit, then on to the first LEDSnaps PACE bar.

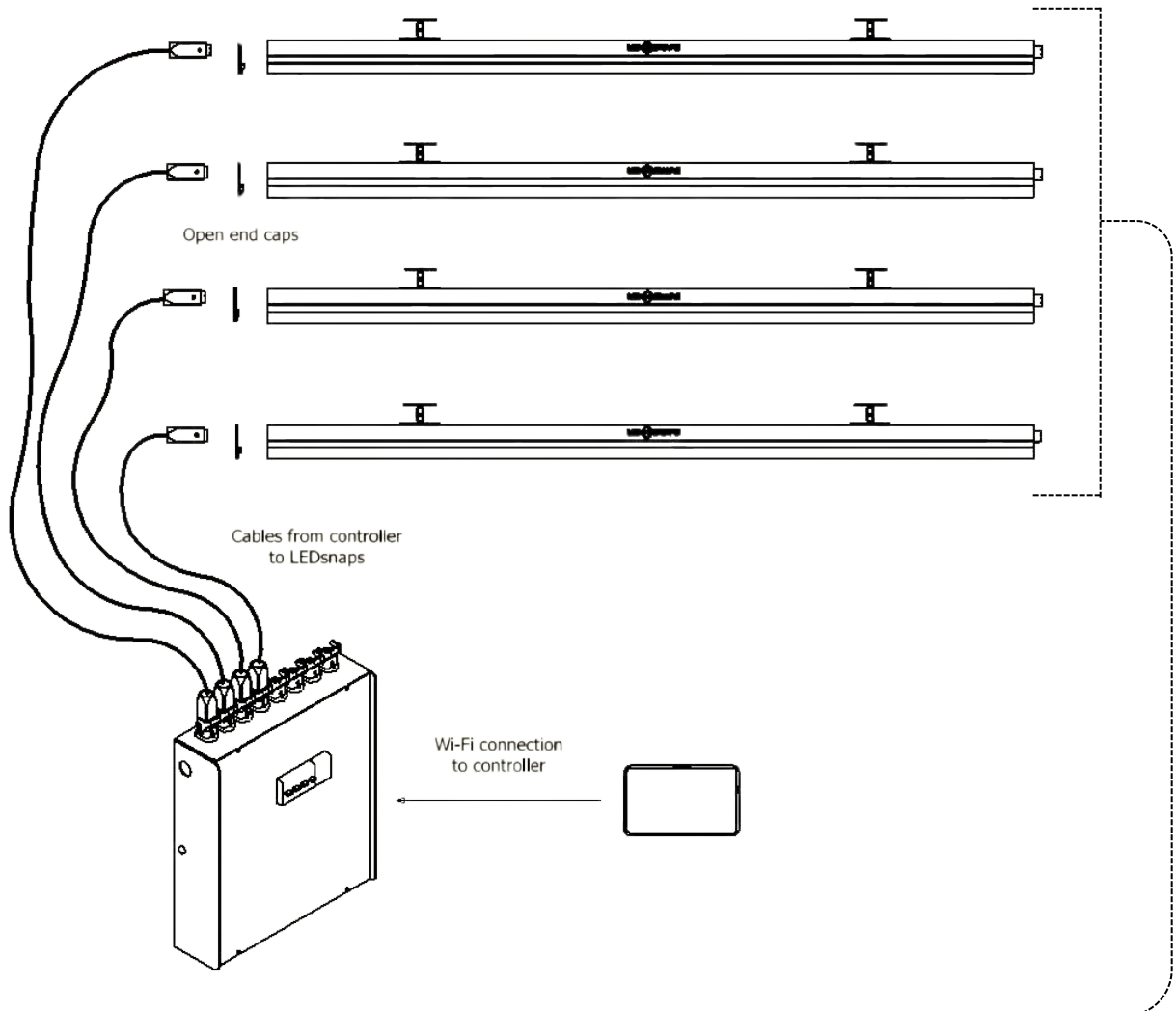

At the end of each LEDSnaps PACE linear run.

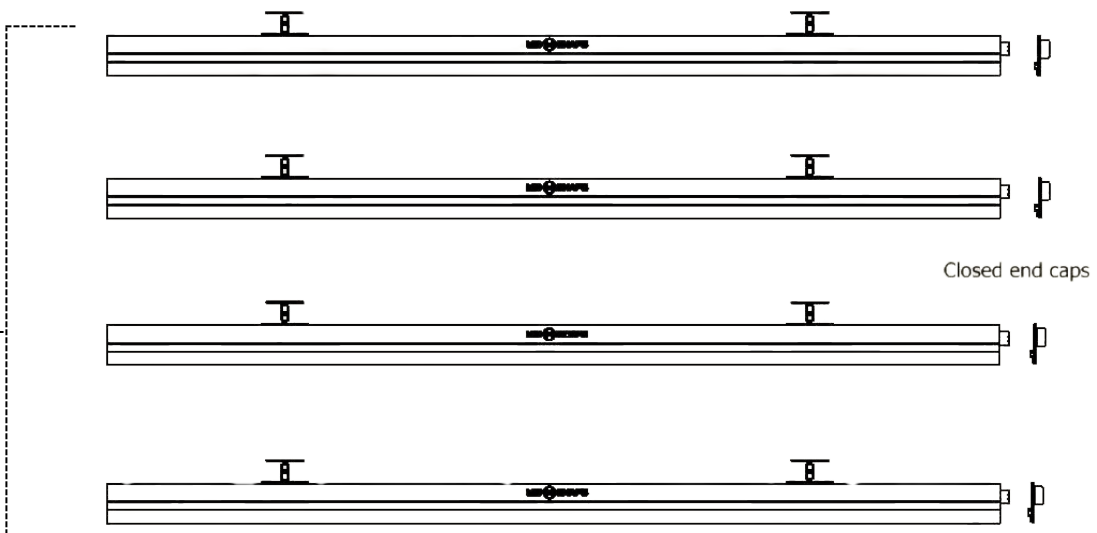

## Support

Should you require any support or have any queries, please contact one of our representatives on the below contact information.

- Email** - info@ledsnaps.com
- Phone** - +44 (0) 1223 423 360
- Headquarters** - Units 21-24 Creative Enterprise Quarter  
Javelin Way  
Ashford, Kent  
TN24 8FN



To aid with the installation of the Flat Ceiling Hardware, below is a 1:1 installation template. This can be cut out and used to follow an installation line and mark the hole location for your installation hardware.

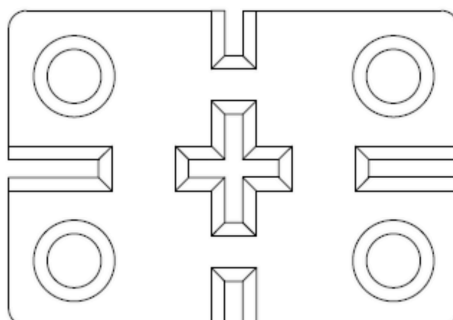

## Product Specifications

### PACE 1200

Input Voltage – 230 Volt  $\pm 10\%$  50 Hz  
Input Current – 0.3 Amps  
Operation Voltage – 12V DC  
Operation Current –  $\leq 1.5$  Amps  
Over current protection  
Over Voltage protection  
Over Temperature protection  
Built-in Meanwell power supply  
24 RGB LED Pixels per PACE 1200

Net dimensions – 1212 x 53 x 35mm  
Net weight – 1.2kg

### PACE 600

Input Voltage – 230 Volt  $\pm 10\%$  50 Hz  
Input Current – 0.3 Amps  
Operation Voltage – 12V DC  
Operation Current –  $\leq 0.75$  Amps  
Over current protection  
Over Voltage protection  
Over Temperature protection  
Built-in Meanwell power supply  
12 RGB LED Pixels per PACE 600

Net dimensions – 612 x 53 x 35mm  
Net weight – 0.75kg

### PACE 400

Input Voltage – 230 Volt  $\pm 10\%$  50 Hz  
Input Current – 0.3 Amps  
Operation Voltage – 12V DC  
Operation Current –  $\leq 0.5$  Amps  
Over current protection  
Over Voltage protection  
Over Temperature protection  
Built-in Meanwell power supply  
8 RGB LED Pixels per PACE 400

Net dimensions – 412 x 53 x 35mm  
Net weight – 0.55kg

### PACE 1200 Top Input

Input Voltage – 230 Volt  $\pm 10\%$  50 Hz  
Input Current – 0.3 Amps  
Operation Voltage – 12V DC  
Operation Current –  $\leq 1.5$  Amps  
Over current protection  
Over Voltage protection  
Over Temperature protection  
Built-in Meanwell power supply  
24 RGB LED Pixels per PACE 1200

Net dimensions – 1212 x 83 x 35mm  
Net weight – 1.24kg

### PACE 1200 Top Output

Input Voltage – 230 Volt  $\pm 10\%$  50 Hz  
Input Current – 0.3 Amps  
Operation Voltage – 12V DC  
Operation Current –  $\leq 1.5$  Amps  
Over current protection  
Over Voltage protection  
Over Temperature protection  
Built-in Meanwell power supply  
24 RGB LED Pixels per PACE 1200

Net dimensions – 1212 x 83 x 35mm  
Net weight – 1.24kg

### PACE 600 Top Input

Input Voltage – 230 Volt  $\pm 10\%$  50 Hz  
Input Current – 0.3 Amps  
Operation Voltage – 12V DC  
Operation Current –  $\leq 0.75$  Amps  
Over current protection  
Over Voltage protection  
Over Temperature protection  
Built-in Meanwell power supply  
12 RGB LED Pixels per PACE 600

Net dimensions – 612 x 83 x 35mm  
Net weight – 1.1kg

### PACE 600 Top Output

Input Voltage – 230 Volt ±10% 50 Hz  
Input Current – 0.3 Amps  
Operation Voltage – 12V DC  
Operation Current – ≤0.75 Amps  
Over current protection  
Over Voltage protection  
Over Temperature protection  
Built-in Meanwell power supply  
12 RGB LED Pixels per PACE 600

Net dimensions – 612 x 83 x 35mm  
Net weight – 1.1kg

### Driver 8 Pro

230 Volt ±10% 50 Hz, 16 Amps maximum  
Idle power <3  
Built-in Meanwell power supply  
4x 8A type C Miniature Circuit Breakers  
8 Outputs  
IP20 – For indoor use only  
20 PACE bars per output maximum  
Total load to not exceed 80 PACE bars

Net dimensions – 400 x 350 x 99mm  
Net weight – 5kg

### Driver 4 Pro

230 Volt ±10% 50 Hz, 16 Amps maximum  
Idle power <3  
Built-in Meanwell power supply  
2x 8A type C Miniature Circuit Breakers  
4 Outputs  
IP20 – For indoor use only  
20 PACE bars per output maximum  
Total load to not exceed 40 PACE bars

Net dimensions – 400 x 350 x 99mm  
Net weight – 5kg

### Flat Corner PACE (Left & Right)

Input Voltage – 230 Volt ±10% 50 Hz  
Input Current – 0.3 Amps  
Operation Voltage – 12V DC  
Operation Current – ≤0.67 Amps  
Over current protection  
Over Voltage protection  
Over Temperature protection  
Built-in Meanwell power supply  
4 RGB LED Pixels per Flat Corner PACE

Net dimensions – 121 x 121 x 35mm  
Net weight – 0.3kg

### Inside Corner PACE

Input Voltage – 230 Volt ±10% 50 Hz  
Input Current – 0.3 Amps  
Operation Voltage – 12V DC  
Operation Current – ≤0.67 Amps  
Over current protection  
Over Voltage protection  
Over Temperature protection  
Built-in Meanwell power supply  
4 RGB LED Pixels per Flat Corner PACE

Net dimensions – 133 x 133 x 35mm  
Net weight – 0.3kg

### LEDsnaps Control Panel

10" wall mounted tablet  
Supplied with a DC adaptor with UK/EU/US plug.  
PoE compatible (additional adaptor required)  
LEDsnaps app rooted to the firmware and pre-paired with your Driver 4/8 Pro.

Net dimensions – 212 x 147 x 27mm  
Net weight – 0.73kg